



FMDL-SERIES SINGLE & DOUBLE EAGLE BEAK FORK-MOUNTED DRUM LIFTERS

INSTRUCTION MANUAL



FMDL-850 & FMDL-1500



FMDL-2000 & FMDL-3000

VESTIL MANUFACTURING CORP.

2999 NORTH WAYNE STREET, P.O. BOX 507, ANGOLA, IN 46703

TELEPHONE: (260) 665-7586 -OR- TOLL FREE (800) 348-0868

FAX: (260) 665-1339

URL: WWW.VESTILMFG.COM

EMAIL: SALES@VESTIL.COM

NOTE: COMPLIANCE WITH REGULATIONS, CODES, AND/OR STATUTORY (NON-VOLUNTARY) STANDARDS ENFORCED IN THE LOCATION WHERE THE DEVICE IS USED IS EXCLUSIVELY THE RESPONSIBILITY OF THE END-USER. IF LAW, ENFORCED WHERE THE DRUM LIFTER IS USED, CONTRADICTS AN INSTRUCTION(S) OR PART OF AN INSTRUCTION(S) AND THEREFORE REQUIRES YOU TO DEPART FROM THESE DIRECTIONS, VESTIL IS NOT RESPONSIBLE FOR ANY CONSEQUENTIAL DAMAGES SUSTAINED AS A RESULT OF THE INSTALLATION.

Table of Contents

Product Introduction.....	2
Safety Principles.....	3
Safety Guidelines.....	3
Use Instructions.....	6
Center-of-Gravity Information.....	8
Maintenance Recommendations.....	9-10

Table of Figures

Fig. 1A "Exploded parts diagram (FMDL)".....	4
Fig. 1B "Labeled photograph".....	5
Fig. 2 "Cam lock parts diagram and parts list".....	6
Fig. 4 "FPDL-8-L Exploded parts diagram and parts list".....	7

PRODUCT INTRODUCTION



Thank you for purchasing an FMDL-or-FMDDL-series fork-mounted drum lifter (“drum lifter” or “lifter”) made by Vestil Manufacturing Corporation. Our drum lifters are durable, high-quality products rigorously engineered for dependability and simplicity. Although use and maintenance procedures are relatively intuitive, any person who might use or maintain this product must be familiar with the instructions provided in this manual. Dimensions and other product specifications appear in the following table:

Model	Description	Compatible Drums	Maximum Rated Load in Pounds (~kg)	Overall Dimensions in Inches (~cm)	Net Weight in Pounds (~kg)
FMDL-850 (light duty)	One (1) drum engager; single mast	<ul style="list-style-type: none"> • 30 & 55 gallon • Open & closed head • Steel & plastic 	750 (~341kg)	31 x 34 x 35 ~(79 x 86 x 89)cm	160 (~73kg)
FMDL-1500	One (1) drum engager; single mast	<ul style="list-style-type: none"> • 30 & 55 gallon • Open & closed head • Steel, plastic, & fiber 	1,500 (~682kg)	33 x 47 x 37 ~(84 x 119 x 94)cm	340 (~155kg)
FMDL-2000	Two (2) drum engagers; single mast	<ul style="list-style-type: none"> • 30 & 55 gallon • Open & closed head • Steel, plastic, & fiber 	2,000 (~909kg)	33 x 47 x 37 ~(84 x 119 x 94)cm	366 (~166kg)
FMDDL-1700 (light duty; attaches directly to fork truck carriage)	One (1) drum lip engager	<ul style="list-style-type: none"> • 30 & 55 gallon • Open & closed head • Steel & plastic 	1,500 (~682kg)	38 x 34 x 35 ~(97 x 86 x 89)cm	207 (~94kg)
FMDDL-3000	Two (2) drum engagers [1 per mast]; 2 masts	<ul style="list-style-type: none"> • 30 & 55 gallon • Open & closed head • Steel, plastic, & fiber 	3,000 (~1,364kg)	33 x 47 x 37 ~(84 x 119 x 94)cm	430 (~195kg)
FMDDL-4000	Two (2) Pincer-type drum lip engaging devices per mast; 2 masts	<ul style="list-style-type: none"> • 30 & 55 gallon • Open & closed head • Steel, plastic, & fiber 	4,000 (~1,818kg)	33 x 47 x 37 ~(84 x 119 x 94)cm	483 (~220kg)

NOTE: FMDL-850 and FMDDL-1700 model lifters are light duty units. They are designed to handle NO MORE THAN 100 drums per month.

Vestil Manufacturing Corp. created this manual to acquaint persons authorized to use and/or maintain this drum handling device with safe use and maintenance procedures. **Employers are responsible for instructing employees to use the product properly. Each person(s), who might use or perform maintenance on the drum lifter, must read and understand every instruction BEFORE using or performing maintenance activities. Users should have access to the manual at all times** and should routinely review the directions.

Although Vestil diligently strives to identify foreseeable hazardous situations, this manual cannot address every conceivable danger. The end-user is ultimately responsible for exercising sound judgment at all times.

SAFETY PRINCIPLES This manual addresses the specifications, features, and capabilities of 2 product lines: 1) FMDL-series lifters; and 2) FMDDL-series lifters. Each lifter conforms to the generalized specifications disclosed in this manual and fulfills our demanding standards for quality, safety and durability.

Vestil Manufacturing Corp. recognizes the critical importance of workplace safety. Each person who **might** participate in the use or maintenance of the product must read this manual **and fully understand the directions BEFORE using or performing maintenance on the drum lifter. If you do not understand an instruction, ask your supervisor or employer for assistance. Failure to adhere to the directions in this manual might result in serious personal injury or even death.**

Vestil is **not liable** for any injury or property damage that occurs as a consequence of failing to apply either: 1) the instructions that appear in this manual; or 2) the information provided on labels affixed to the product. Furthermore, failure to exercise good judgment and common sense might result in property damage, serious personal injury or death. Such failure is solely the fault of the person(s) who acted without good judgment; it is **not another responsibility delegated to manufacturers.**

This manual uses SIGNAL WORDS to classify personal injury risks and situations that might lead to property damage, as well as to draw attention to safety message(s). The reader must understand that each signal word indicates the seriousness of the described hazard.



Identifies a hazardous situation which, if not avoided, WILL result in DEATH or SERIOUS INJURY. Use of this signal word is limited to the most extreme situations.



Identifies a hazardous situation which, if not avoided, COULD result in DEATH or SERIOUS INJURY.



Indicates a hazardous situation which, if not avoided, COULD result in MINOR or MODERATE injury.



Identifies practices likely to result in product/property damage, such as operation that might damage the drum lifter.

SAFETY GUIDELINES

Failure to read and understand the instructions included in this manual before using or servicing the drum lifter constitutes misuse of the product. Study the entire manual before you install the product. Read the manual to refresh your understanding of the safe use and inspection procedures explained on p. 9. DO NOT attempt to resolve any problem(s) with the lifter unless you are both authorized to do so and certain that it will be safe to use afterwards.



Electrocution might result if any part of the lifter or fork truck contacts electrified wires. Reduce the likelihood of electrocution by applying **common sense:**

- DO NOT *contact* electrified wires with any part of the drum lifter, drum or fork truck;
- DO NOT use or store the drum lifter in an area where contact with electrified wires is likely or possible;
- Before mounting the lifter on the forks of a forklift, inspect the usage area for unusual conditions and implement precautions that account for those conditions.



If this product is used improperly or carelessly, the operator and/or bystander(s) cause might sustain serious personal injuries or could be killed. To reduce the likelihood of injury:

- DO NOT exceed the maximum rated load of your lifter (see Label on product; also see table on p. 2).
- DO NOT use a structurally compromised drum lifter. Examples of structural damage include: 1) missing, broken or significantly bent drum-engaging arms; 2) broken, missing, or deformed safety chain/strap; 3) damaged or broken fork pockets. Inspect the drum lifter according to the inspection instructions on p. 9-10. Replace each part that fails to pass an inspection. DO NOT use the drum lifter until authorized maintenance personnel approve it for service.
- DO NOT stand, or allow other persons to stand, beneath any part of the lifter or drum.
- DO NOT use the lifter to transport *anything* but drums appropriate for the capabilities of your specific lifter model according to the table on p. 2.
- **ONLY transport drums in a manner consistent with the fork truck training you received.**
- DO NOT use the lifter to transport a drum(s) over rough, uneven, or damaged terrain.
- DO NOT modify the drum lifter or any component of the lifter in any way **UNLESS** you first obtain written approval from Vestil. Unauthorized modification(s) might make the lifter unsafe to use.
- DO NOT use the lifter **UNLESS** all product labels are readable and undamaged.

FIG. 1A: Exploded parts diagram (FMDDL-series shown; parts list on next page)

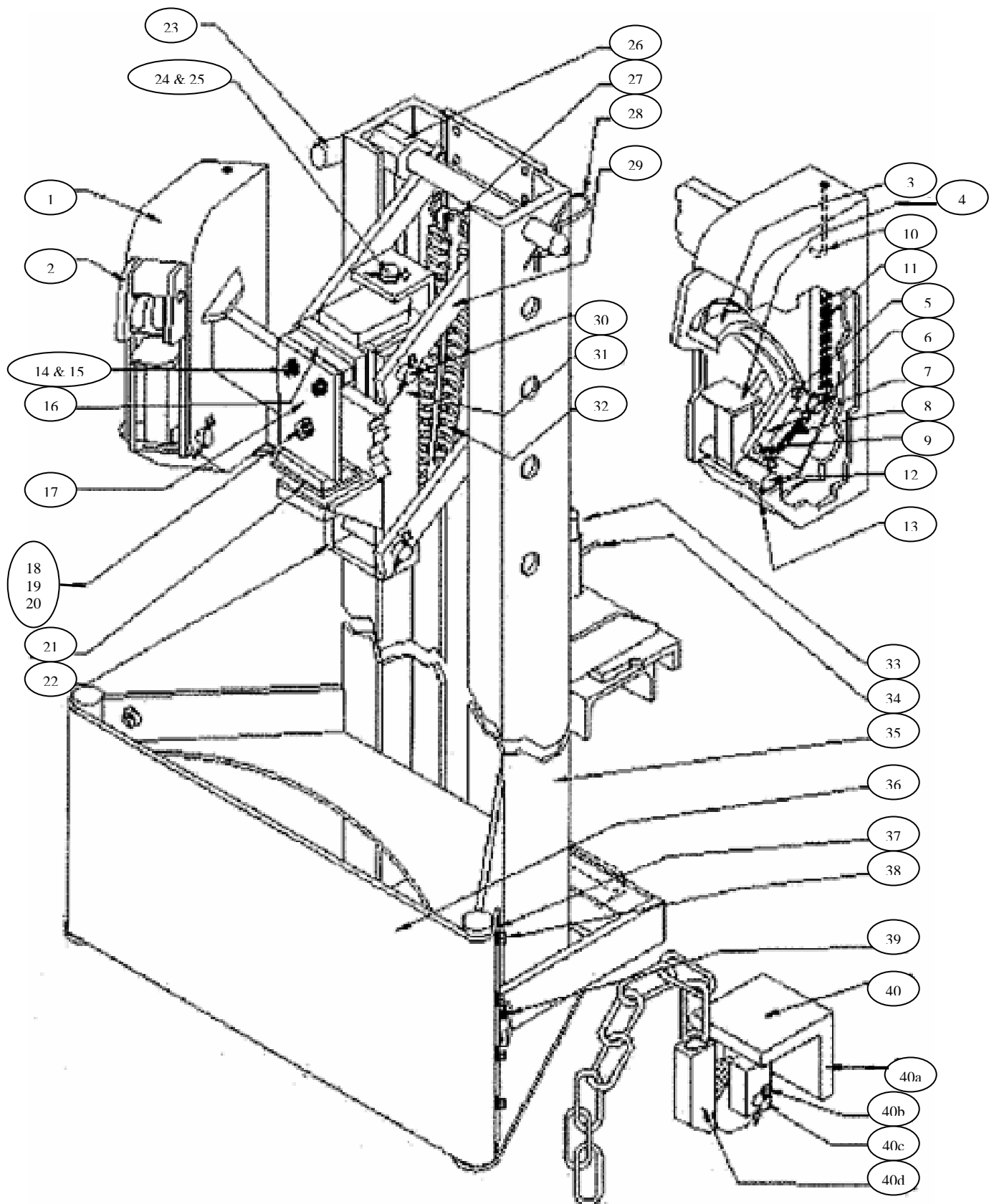
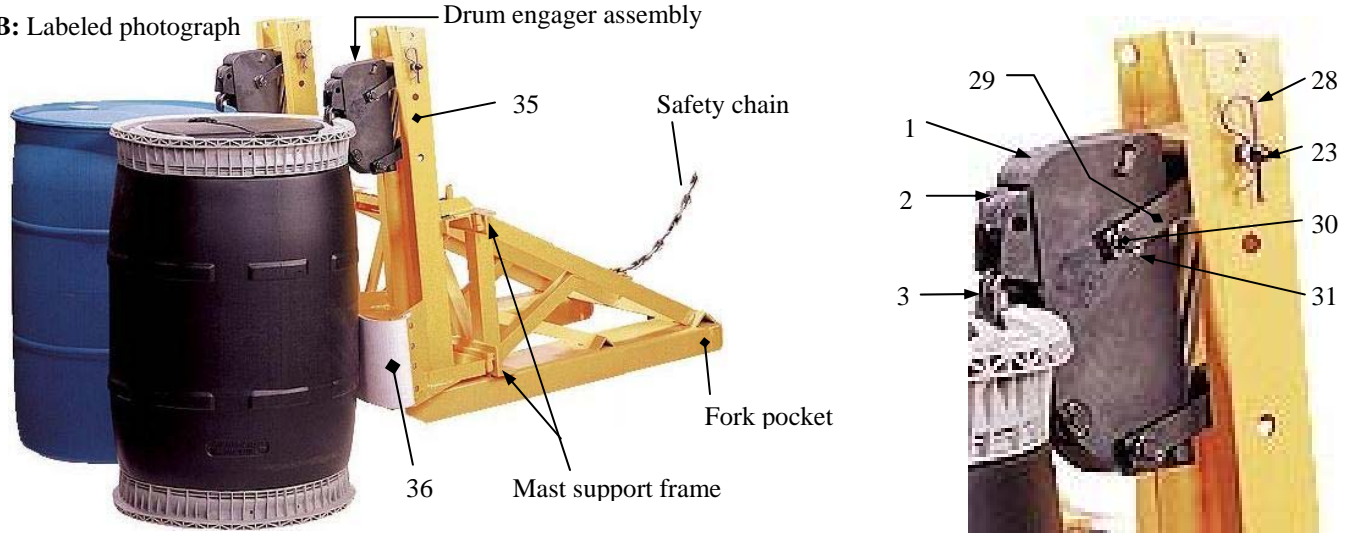

FIG 1B: Labeled photograph



Parts list [NOTE: Item numbers 14-22 & 24, 25 are only present in FMDDL-series lifters]:

Item No.	Part No.	Description	Quantity	Item No.	Part No.	Description	Quantity
"Drum engager" assembly (#1 - 13)				23	19106-1	Height adjustment pin	1
1	6202	Outer housing	1	24	15106-1	Mounting pin	1
2	7902	Inner housing	2	25	6006-CP	Cotter pin	2
3	1007	Upper jaw	2	26	1700-7	Adjustment slide	2
4	5107	Lower jaw	2	27	8996	Clevis spring hook	1
5	72041	Link pin (upper jaw)	2	28	7016	Cotter pin	1
6	10061	Upper jaw housing pin	2	29	3202	Mounting link	2
7	70091	Jaw link pin	4	30	17006-1	Mounting assembly link pin	2
8	4306	Jaw spring	2	31	6006-CP	Cotter pin	4
9	62041	Lower jaw link pin	2	32	4206	Link spring	2
10	9996	Housing hook spring	2	33	36006-1	Carriage lock pin	1
11	2206	Housing spring	2	34	1506	Carriage lock roller pin	1
12	18006-1	Housing pin	2	35	4902	Drum engager supporting mast	1 or 2 (see table p. 2)
13	6006-CP	Cotter pin	4	36	2516	Malleable cradle belt	1
					3516	Composite material	1
					8516	Rubber	1
Drum engager mounting assembly (FMDDL only)							
Item numbers 14-22 & 24, 25				37	12200-4	Clamp	2
14	1016	3/8 in. – 16 x 1¼ in. cap screw	2	38	2906	5/16 in. – 18 hex nut	8
					4017	5/16 in. x 1¼ in. bolt	8
15	7706	3/8 in. lock washer	2	39	6902	Clamp adjustment pin	1
					3906	5/8 in. -11 hex nut	2
					7701	5/8 in. lock washer	1
16	10203-1	Drum engager mounting spacer	1	40	0504	Safety chain cam lock assembly	1
17	9202	Drum engager mounting	1	40a	0504a	Locking safety clamp	1
18	2016	½ in. – 13 x 1¼ in. trunion bolt	1	40b	6006-CP	Cotter pin	2
19	1906	½ in. -13 lock nut	1	40c	4006-1	lock pin	1
20	10001	Bushing	1	40d	0504d	Cam of 24 in. locking safety clamp	1
21	16009-1	Drum engager mounting wear plate	1	Not shown	WLG	12 oz. lithium grease (white)	
22	7202	Drum engager mounting bracket	1				

FIG. 2: Cam lock parts diagram (models FMDL-1500 & 2000, and FMDDL-3000 & 4000)
 This device functions as a tine lock; it secures the 4 models listed above to the tines of a fork lift.

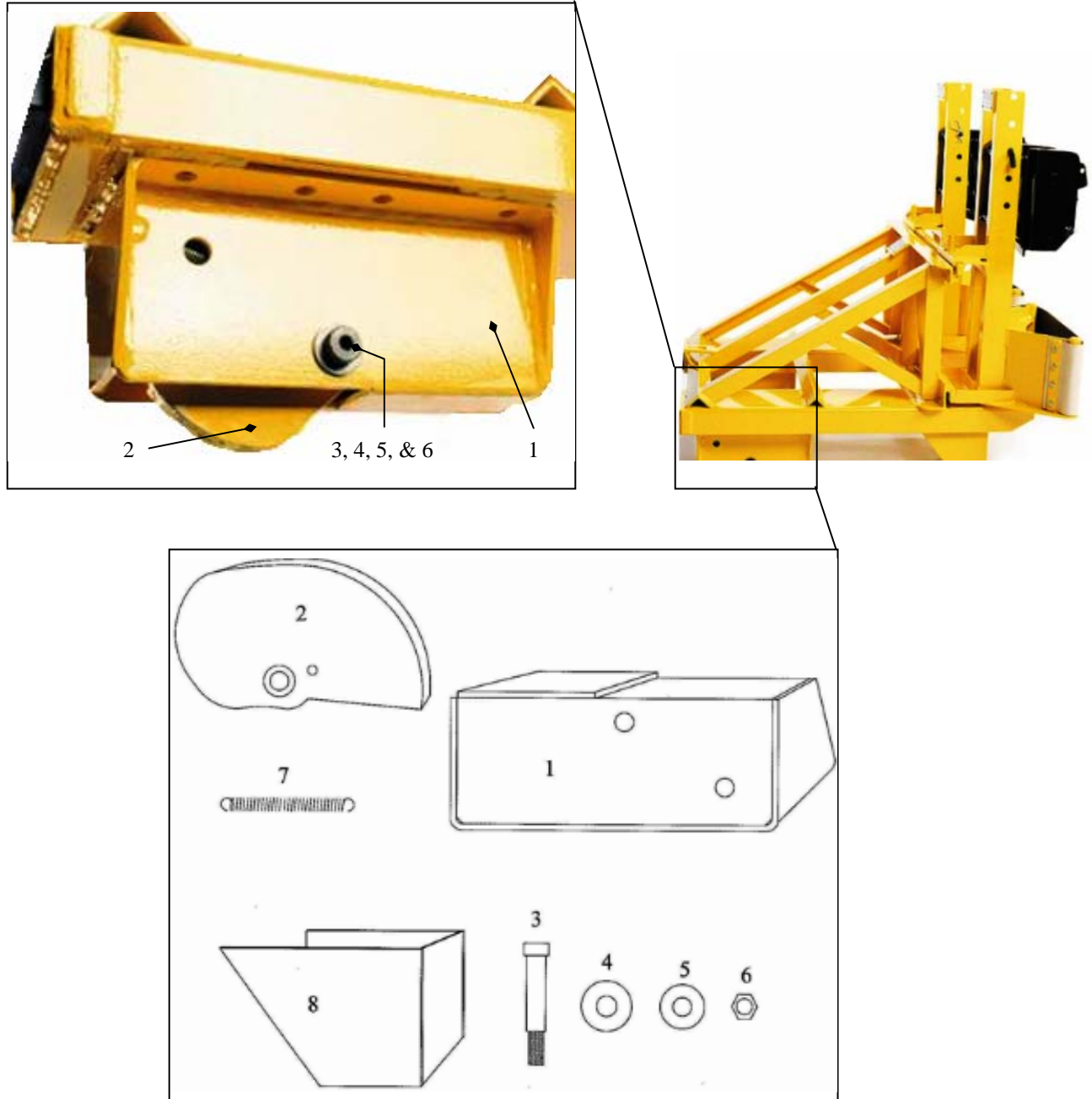

Item no.	Part no.	Description	Quantity
1	QCH2.5	Cam housing	2
2	QCC2.5	Single cams	2
3	343SHB	¾ in. x 3 in. socket shoulder bolts	2
4	34FW	¾ in. fender washer	2
5	58FW	5/8 in. fender washer	2
6	48SLN	5/8 in. lock nut	2
7	KH100799	Spring	4
8	QCFPS	Fork pocket support	2

Use Instructions (Fork-mounted models: all but FMDL-1700)

Step 1: Adjust the positions of your lift truck's forks/tines to match the spacing between the fork pockets. Apply the operation procedures learned during your lift truck training program to properly adjust fork position.

Step 2: Mount the drum lifter on the forks of your lift truck. Slowly drive the truck forward until the forks contact the ends of the fork pockets. For models equipped with cam locks, the lifter must be fully and evenly supported by the floor to keep the cam lock open so that the forks can enter the fork pockets.

Step 3: Connect the drum lifter to the fork truck by attaching the safety chain to the fork carriage. Wrap the chain around the fork carriage and then fasten the snap hook to the chain **without slack**. If your lifter includes a bracket attached to the free end of the safety chain, wrap the chain around the carriage, and attach the bracket to the top of the carriage **without slack**. The chain must not be able to disconnect from the carriage without deliberate effort. For instance, the chain must not be able to slide free of the carriage. If different procedures are applied at your worksite, follow those procedures instead of these directions.

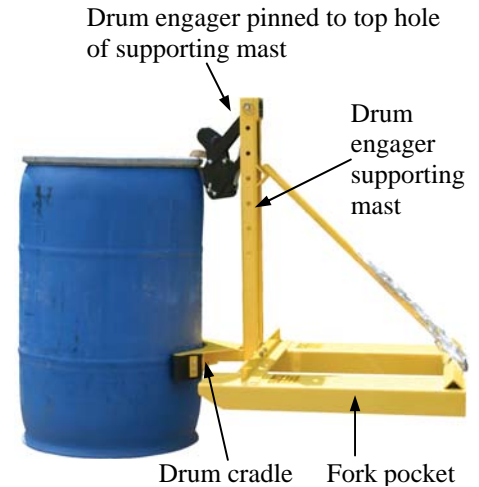

WARNING The chain and cam lock assembly are essential safety-enhancing features. Use the chain to connect the drum lifter to the *carriage* of your fork truck. Wrap the chain around the carriage and fasten the free end to the chain, or the bracket to the top of the carriage, **with no slack**. *The chain will not prevent the drum lifter from sliding off of the forks if it is improperly connected to the fork carriage.*

NOTICE Slowly lower the forks to avoid damaging impacts between the floor/ground and the drum or lifter.

Step 4 Engage the selected drum with the lifter: To properly engage a 55 gallon drum, adjust the position of the drum engager so that it is pinned to the top hole in the supporting mast. To engage smaller drums, when close to the drum, lower the carriage as far as possible; then remove the adjustment pin, (item # 23 on p. 5). Lower or raise the engager mounting link (item #29 on p. 5) mechanism so that the lower jaws are slightly below the rim of the drum. It is advisable to have the cradle contact the drum near its base. Raise the forks just a few inches off of the ground/floor, and tilt the mast of the fork truck forward. Drive slowly towards the selected drum until the lower jaw of the drum engager contacts the side of the drum just beneath the lip.

Step 5 Grasp the lip of the drum: Slowly raise the forks until the upper jaw engages the top of the drum lip. Continue to raise the forks until the drum is elevated a few inches above the floor/ground.

Step 6 Transport the drum: Straighten the mast and transport the drum to the desired unloading location. Raise the forks as required by conditions along the travel path.

Step 7 Release the drum: Lower the forks until the drum is just a few inches above the floor. Tilt the fork truck mast forward. Slowly lower the forks until the jaws disengage the lip of the drum and the drum is fully supported by the floor/ground.

FMDL-1700 model only:

Remove tines/forks from the forklift carriage. Set the upper mast support bracket on the top rail of the fork truck carriage, in the location where the bottom mounting bracket of the EG4DCM can fit into the cut-out portion of the bottom rail of the carriage. Slide the FMDL-1700 unit slightly to the left or the right of center, until both mounting brackets are seat firmly on the carriage.

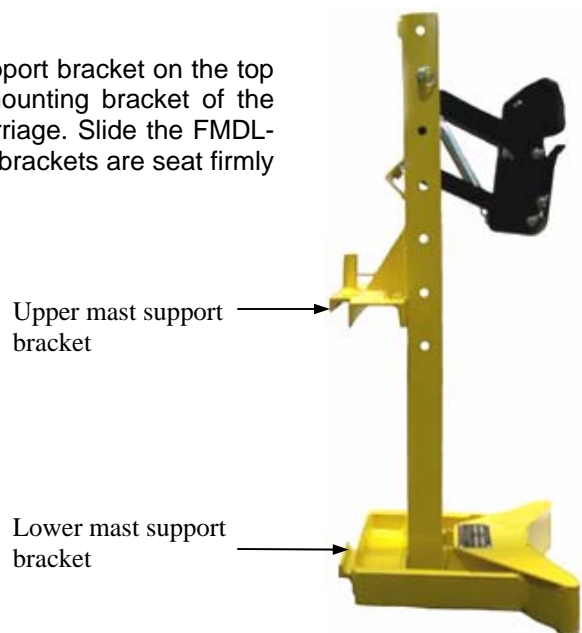

Center-of-Gravity (CoG) information

CoG has both a vertical component and a horizontal component. Both components lie along the center line (dotted).

VERTICAL CENTER OF GRAVITY:

The distance from point A to point V.

FMDL-CM	18¼ inches (~46cm)
FMDL-2000	12 inches (~30cm)
FMDL-4000	14 inches (~36cm)

HORIZONTAL CENTER OF GRAVITY:

Distance between point H and point A.

FMDL-2000	30 inches (~76cm)
FMDL-4000	33 inches (~84cm)

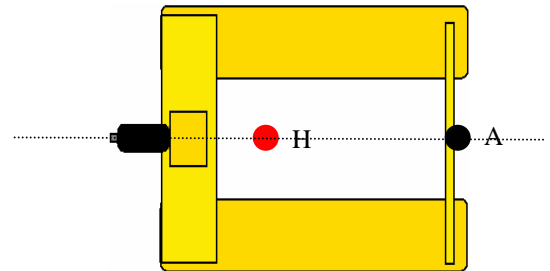

Maintenance Recommendations

Before each use, inspect the listed components:

1. Safety chain and snap hook or bracket (attached to the free end of the safety chain): confirm that the mechanism functions normally. DO NOT use the lifter if the hook/bracket or chain is damaged.
2. Fasteners (hardware): Bolts, nuts, washers, pins, cotter pins;
3. Product labels: all labels should be readable. If a label(s) is unreadable or missing, contact the manufacturer to order a replacement. Manufacturer information appears on the data plate attached to the lifter.

At least once per month, inspect:

1. Fasteners (hardware):
 - Bolts, nuts, washers, pins, cotter pins;
 - Chain and snap hook/bracket;
2. Fork pockets and supporting frame: confirm that each pocket is structurally sound, uncorroded and free of rust. Do not use the lifter if the fork pockets are structurally compromised (deformed, warped or cracked), rusted or corroded;
3. Welds: confirm that all welds are intact;
4. Drum engager: upper and lower jaw, cotter pins, trunion bolts, springs, pins, snap rings. Apply lubricant (white lithium grease);
5. Manufacturer data plate(s): verify presence and readability; AND
6. Overall condition of drum lifter: the structure should be clean, square and rigid, and free of rust and corrosion. Remove dirt and debris. Do not use the lifter if the supporting frame and/or one or both grippers are excessively rusted or corroded. Lubricate the top and bottom rails of the mast support frame (see Fig. 1B on p. 5)) to permit the masts to slide left and right.

Every Three Years:

Replace inner housings and mounting links